

ConSet

Electric Table Lifter



FourWinds e-Office Solution



501-27

Flexibility is key to the new 501-27 series. It is available in three widths and with top brackets measuring just 45cm it accommodates very narrow top sizes. A max load on 125 kg and safety stop feature make this desk complete. With a height range of 54cm to 119cm it is perfect for the smallest to the tallest users. See specifications on page 18-19.



Frame	Item no.	Color	Width
	501-27 7S084	Silver	84 cm
	501-27 7S133	Silver	133 cm
	501-27 7S152	Silver	152 cm
	501-27 7S152-152A	Silver	152 cm

↑
55-120 cm
↓







66-118 cm



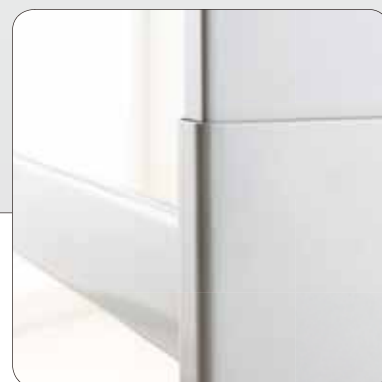

Simplicity and elegance define the 501-17. Sleek modern casters provide mobility when needed and the retractable cable tray offers practical convenience. A very popular choice at a very affordable price. See specifications on page 18-19.

Frame	Item no.	Color	Width
	501-17 7S096	Silver	96 cm
	501-17 7S156	Silver	156 cm



501-7

As experts in the field of single-column height adjustable desks, we must admit that we are quite proud of this series. 501-7 is a small computer desk with many uses. An excellent electric height adjustable desk at possibly the lowest price on the market is the ConSet reality. Built-in locking casters provide a mobile desk frame that can be used as a stand-alone unit or for group setups. The max load of 70 kg allows the frame to be used with a variety of top designs. See specifications on page 18-19.

Frame	Item no.	Color	Width
	501-77S	Silver	94 cm
	501-77B	Black	94 cm

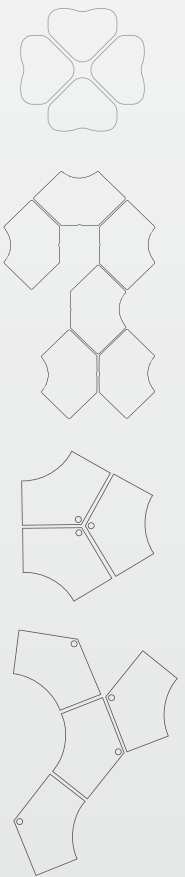



501-19 Wall creates a functional and attractive workstation. The wall brackets attach easily to the leg enabling you to secure the frame to a wall. Place the column directly on the floor or raise it a few centimeters so the floor can be cleaned. This is especially useful in medical settings. Without the need for floor brackets maximum space can be achieved beneath the work surface. The sturdy frame has a max load of 100 kgs.

See specifications on page 18-19.

Frame	Item no.	Color	Width
	501-19 7SWS	Silver	90 cm
	501-19 7BWS	Black	90 cm
	501-23 7SWS2	Silver	Min. 180 cm
	501-23 7BWS2	Black	Min. 180 cm
	501-23 7SWS3	Silver	Min. 270 cm
	501-23 7BWS3	Black	Min. 270 cm



Environment

At ConSet we think it is important to minimize environmental impacts. We want to take responsibility for ensuring that our products are made respecting the environment. We do this in several ways. Our wood products are FSC labelled, which is a guarantee that you can buy our table tops and other wood products in good conscience.

FSC criteria prohibits conversion of forests or any other natural habitat.

All electronic components meet ROHS framework for the reduction of hazardous substances in electronics, whereby the environmental impact is minimized. ConSet arranges for responsible disposal of electronics. Through Elretur system (Denmark) , we ensure that electronic waste is managed environmentally responsible under the WEEE directive. All ConSet products covered by the WEEE Directive are marked with the symbol 

Read more about the environment on conset.com

CE Marking

All ConSet electric height adjustable desk frames are CE marked in collaboration with the Technological Institute in Denmark. CE marking is a requirement for height adjustable desk frames and it allows you to be sure that the producer has been through all aspects of security risk.

Product Approvals

Strength, durability and stability:

EN 527-2: Office furniture - Workplaces and desks - Mechanical safety requirements clause 3

EN 527-3: Office furniture - Workplaces and desks - Methods of Test for the Determination of the stability and the mechanical strength of the structure.

Claim for measurements:

EN 527-1: Office furniture - Workplaces and desks - Dimensions.

Surface:

DS / EN 12720: Furniture - Assessment of surface resistance to cold liquids.

DS / EN 12721: Furniture - Assessment of surface resistance to wet heat.

DS / EN 12722: Furniture - Assessment of surface resistance to dry heat.

Guarantee

The guarantee is valid from the date, you have purchased the product from your dealer.

Parts only against manufacturing defect. Electrical / mechanical parts: 2 years, Other parts: 5 years.

ConSet A / S reserves the right to change design and specifications without notice.

And a little about ConSet

ConSet is a consolidated Danish company, which more than 10 years ago began in a basement in Skjern, Denmark. Our basic philosophy was that ergonomics should not be expensive and still today this is the policy; that ConSet products should not be expensive. We have succeeded quite well and have distribution and subsidiaries throughout the world.







When you buy a ConSet desk or table, you get a product which is original to the smallest detail. We are an engineering company that develops the whole product down to the smallest component. So you get a product developed specifically for its purpose.

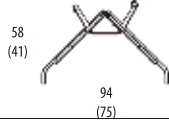

FSC Trademark © 1996
Forest Stewardship Council A.C.

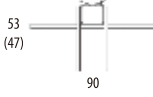

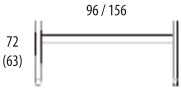
Desk frame specifications

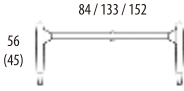
Page	Produktfoto	Drawing () indicates the target of tabletop supporting	Item no.	Color	Min/max height (cm)	Max speed (mm/sec)	Max load (kg)	Frame weight (kg)	Quantity per pallet
3			501-7 7S 501-7 7B	Silver Black	66-118	25	70	30	20
4			501-19 7SWS 501-19 7BWS	Silver Black	66-118	28	100	19	15
2			501-17 7S096 501-17 7S156	Silver Silver	66-118	25	80	28 31	27
1			501-27 7S084 501-27 7S133 501-27 7S152	Silver Silver Silver	55-120	32	125	26 29 30	24

DynaFly - Pure design, Smart look, Durability



In both of functionality and aesthetic design, the new dynamic monitor arm “DynaFly”, combining innovative push-forward compressible spring mechanism and friction balance, which offer the maximize viewing comfort and flexibility.

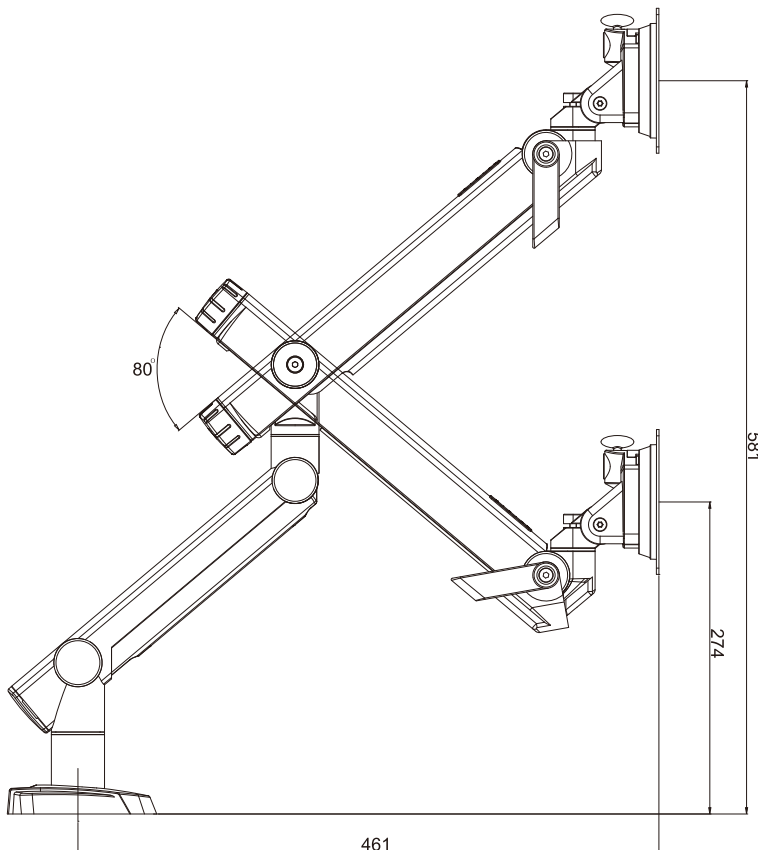

Features:

- High-capacity construction with modern aesthetic contemporary design.
- Unsurpassed screen weight range 2.5kgs (5.5lbs) ~ 15kgs (33lbs).
- Tension controller provides easy monitor balance adjustment.
- Combining of quick release and anti-theft system provide fast and easy monitor installation and effective theft prevention.
- 180° screen turning angle meets most advance IT trend.
- 150° stop mechanism avoids damage from over-rotation.
- Easy and convenient store of tools.
- Integrated cable management.



1 The 100x100/75x75 VESA plate



2 The Quick-release & Anti-Theft mechanism



3 The Weight Indicator

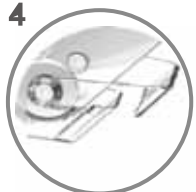

4 The Cable Clip

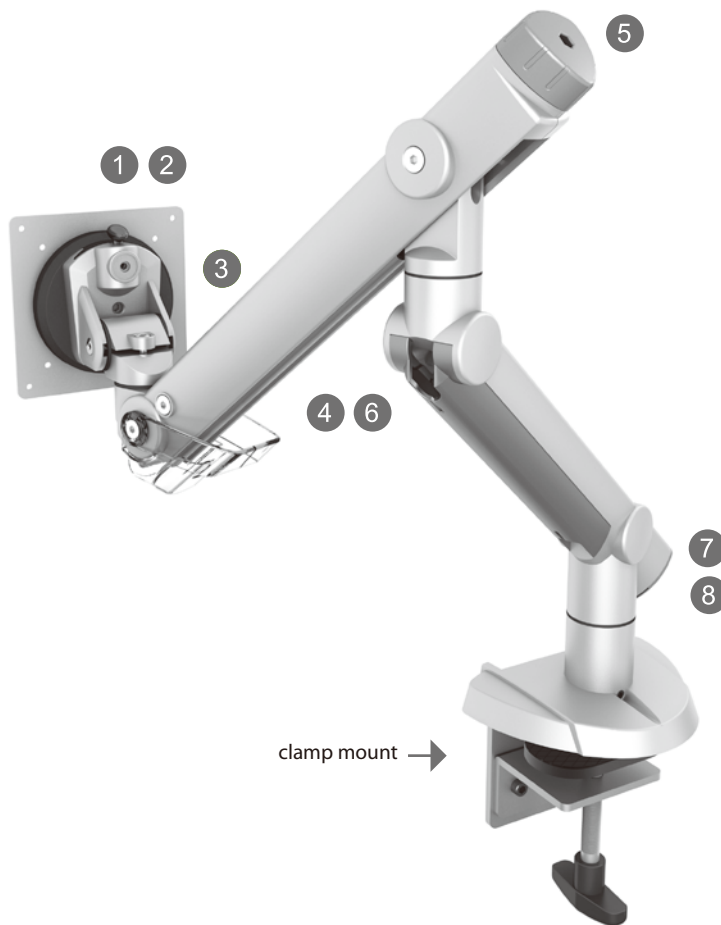

5 The Tension Controller



6 The Cable Management



7 The Tool Storage



8 The 150° stop mechanism

LCD/TV size	Max. Load Capacity	Pan	Rotation	Tilt	Swivel	VESA	Quick Release	Lock (Anti-theft kit)
≤ 27"	15 kg (33lbs)	150°	360°	+90° -40°	±40°	75x75mm 100x100mm	Yes	Option



EGDF-202



EGDF-202DB



EGDF-40

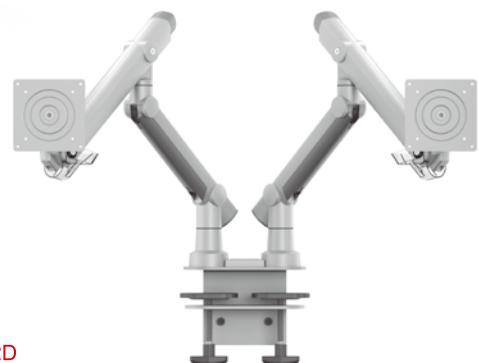

EGDF-202D



LCD Monitor Arm



**Ergonomics Solution
= Working Painlessly**

The goal of LCD monitor arm is to create optimum comfortable and healthy living and working conditions. Great care and fastidiousness are placed in the details of our designs. This LCD monitor arm reviews a number of techniques for avoiding work-related, repetitive stress injuries, long-term incorrect postures & positions and enhancing both the comfort and productivity levels of the workers who adopt them.

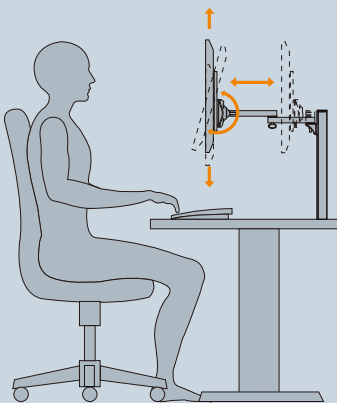

Cable management



Height adjustment



Quick release



Anti-theft kit

- Clamp and Grommet mount type
- Ball joint design
- Aluminum Die-Casting profile
- Front end height adjuster as standard
- Cable management
- Monitor quick release mechanism



W124xD119xH348~492mm
EGL3-200 clamp mount
EGL3-300 grommet mount



W124xD289xH348~492mm
EGL3-201 clamp mount
EGL3-301 grommet mount



W124xD459xH378~522mm
EGL3-202 clamp mount
EGL3-302 grommet mount



W515xD119xH339~484mm
EGL3-201D clamp mount
EGL3-301D grommet mount



W855xD119xH369~514mm
EGL3-202D clamp mount
EGL3-302D grommet mount



● Clamp Mount Type



● Grommet Mount Type



Color



Silver White Black

LCD/TV size	Max. Load Capacity	Pan	Rotation	Tilt	VESA	Quick Release	Lock (Anti-theft kit)	Front end height adjuster
≤ 24"	12 kg (26.4 lbs)	180°	360°	±30°	75x75mm 100x100mm	Yes	Option	15 cm

Slat Wall Mount

- Slat wall Mount Type
- Model : No arm, Single arm, Double arms
- Ball joint design (360° rotation, 30° tilt)
- Monitor weights up to 12 kgs
- Aluminum Die-Casting profile
- Cable management
- Monitor quick release mechanism
- 75/100 mm VESA bracket
- Anti-theft kit as option
- Front end height adjuster as an option



EGL-402D
W901xD116~456xH194mm



EGL-402
W124xD456xH194mm



EGL-401
W124xD286xH164mm



EGL-400
W124xD116xH163mm

Wall Mount

- Wall mount type/ Slat wall mount
- Arm type : No arm, Single arm, Double arms
- Ball joint design
- Aluminum Die-Casting profile
- Cable management
- Monitor quick release mechanism



EGL-102
W124xD456xH194mm



EGL-101
W124xD286xH164mm



EGL-100
W124xD116xH163mm

LCD/TV size	Max. Load Capacity	Pan	Rotation	Tilt	VESA	Quick Release	Lock (Anti-theft kit)	Front end height adjuster
≤ 24"	12 kg (26.4 lbs)	180°	360°	±30°	75x75mm 100x100mm	Yes	Option	Option

runner

Front end height adjustment

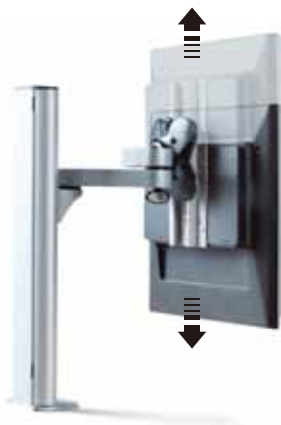
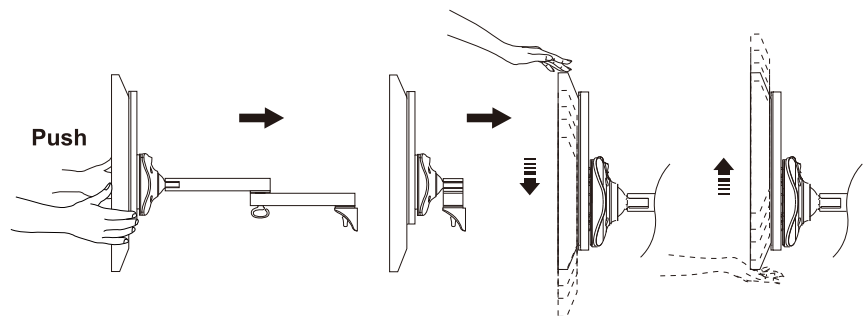

- A front end height adjustment use an optimal solution for a health and comfortable work environment.
- Elevates monitor height to provide more comfort viewing posture.
- Easy adjust, 150mm height adjusts range.
- Aluminum construction



Butterfly model
EGFH-100
120(W) x 225(H) x 19(D)mm

The Butterfly model is for Butterfly LCD Arm only.



Universal model
EGFH-200
120(W) x 225(H) x 19(D)mm

The universal model can fit most of LCD monitor arms in the market.

Adjustable Arm for iPad

TA-111 clamp-fix

TA-131 desk stand

- Loading: ~ 1 kg
- Screen size: 7" ~ 10.1"
- Rotates 180° left and right to accommodate
- Material: high quality aluminium alloy
- Color: white
- Optional with lock

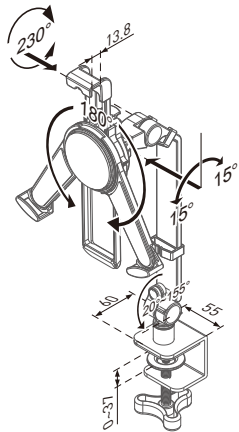

TA-111 clamp-fix

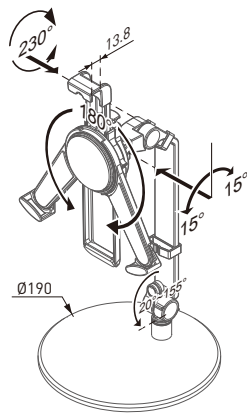

TA-131 desk stand



TA-111 clamp-fix



TA-131 desk stand



Feature

- Free your hands with this iPad stand
- Ergonomically height adjustable suitable viewing position
- Supports iPad and tablets in portrait or landscape mode
iPad easily snaps into holder on the three corners for secure placement

OP-035 VESA Mount Adapter for LED Monitor

- Loading: ~ 6 kgs
- Screen size: 19" ~ 24" LED Monitor
- Connects any VESA-compliant mounting solution with a 75 x 75mm attachment
- Material: iron & plastic ABS
- Color: black

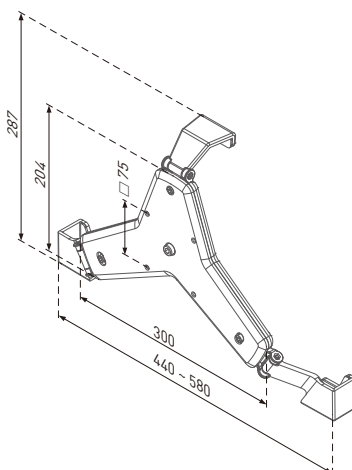

Feature

- Features a lightweight and streamlined design
- Helps LED monitors to be used with various mounting solutions for ergonomic benefits
- LED monitors easily snaps into holder on the three corners for secure placement





EGCP-400

(Track Mount)



silver



EGCP-410

(Fixed wall mount and Fixed under desk mount)

Slim CPU Holder / **EGCP-400, EGCP-410 & EGCP-401**

- Stylish, modular design accommodates various CPU sizes.
- Height range adjusts in $\frac{3}{4}$ " (2 cm) increments.
- CPU stores below work surface to protect against dust and save workspace.
- Easy access to rear of CPU and under-desk storage.
- Anti-Theft lock kit option available.
- Sturdy steel construction.
- Multiple mounting options include fixed wall mount, fixed

Volume Range

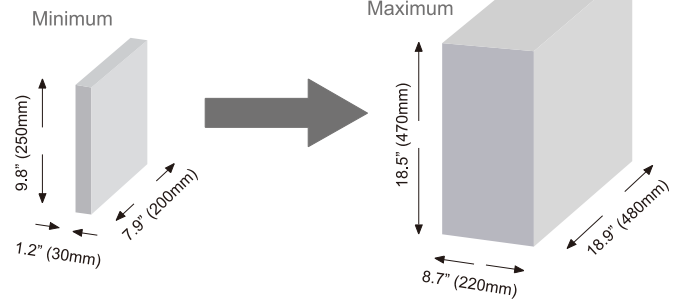

Mounting Options:

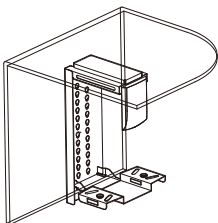

Wall / Side mount

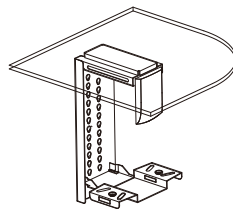

Under desk mount

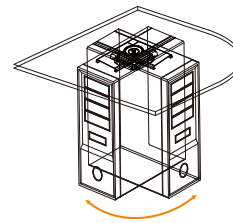

Track mount

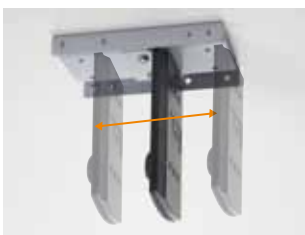

3 side support locations accommodate CPU sizes



2 bottom plate locations accommodate CPU sizes



360° swivel easy access to back CPU



EGCP-401
Anti-theft kit

Xtra LED Flexible Reading Light (2.5W / 5W)

1) 2 different LED modules

- With 40° optical lens



- With tempered glass surface and diffuser



2) Installation: 6 different fixtures

BS2085 & BS1225



BS2086



BS2087



BS2088 & BS1228



BS2084 & BS1224





BS2089 & BS1229



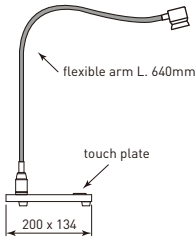

Xtra Desk LED Flexible Light | [BS1229](#) & [BS2089](#)

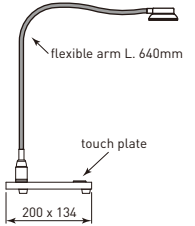
Illustration	Article Code	Model	Description
	09.436.131	BS1229-64NA-NW	<p>1 LED (2.5 W), neutral white, 40° optical lens</p> <p>arm L. 640mm, matt silver</p>
			
	09.289.131	BS2089-64NA-NW	<p>2 LEDs (5 W), neutral white, with glass diffuser</p> <p>arm L. 640mm, matt silver</p>
			

• Complete with ADC70T3.1-3 LED power supply & 3-step touch dimmer



Xtra Workstation LED Flexible Light | BS2086 & BS2087



- Application: office desk, workstation
- Solid aluminium housing, steel flexible arm
- Aluminium grommet / mounting bracket
- With mirror reflector & glass diffuser
- BS2086 - with ADC70T3.1-3 LED power supply and 3-step touch dimmer
- BS2087 - with ADC70IR.1-3 LED power supply and IR sensor switch

1) Grommet mounting (BS2086)

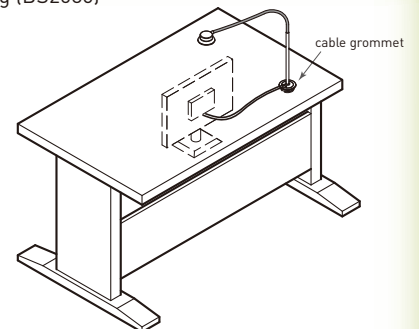

2) Slat wall mounting (BS2087)

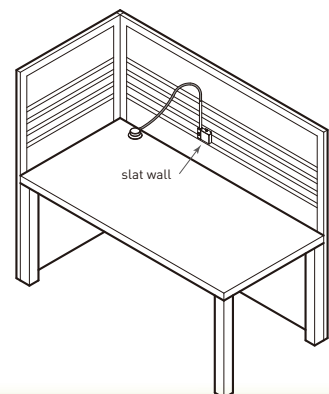



Xtra Workstation LED Flexible Light | **BS2086 & BS2087**

Illustration	Article Code	Model	Description
	09.286.132	BS2086-64NA-NW	grommet mounting, Ø60mm drillhole, with touch base, matt silver arm L. 640mm neutral white, glass diffuser 2 LEDs (5W)
	09.287.132	BS2087-64NA-NW	slat wall mounting, with IR sensor lens, matt silver arm L. 640mm neutral white, glass diffuser 2 LEDs (5W)

BS2086

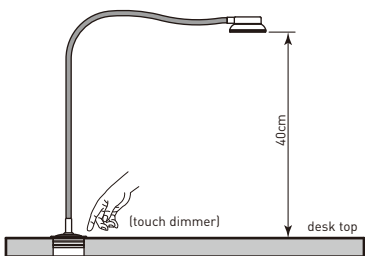

BS2087

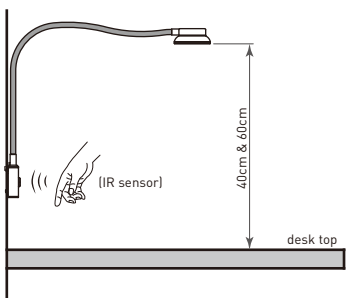



Xtra Spring-clip LED Flexible Light | BS1224 & BS2084

Illustration	Article Code	Model	Description
	09.437.131	BS1224-64NA-NW	<p>1 LED (2.5 W), neutral white, 40° optical lens</p> <p>arm L. 640mm, matt silver</p>
	09.291.131	BS2084-64NA-NW	<p>2 LEDs (5 W), neutral white, glass diffuser</p> <p>arm L. 640mm, matt silver</p>

- Complete with ADC70T3.1-3 LED power supply and 3-step touch dimmer



Xtra Clamp-fix LED Flexible Light | BS1228 & BS2088

Illustration	Article Code	Model	Description
	09.438.131	BS1228-64NA-NW	1 LED (2.5 W), neutral white, 40° optical lens arm L. 640mm, matt silver
	09.288.131	BS2088-64NA-NW	2 LEDs (5 W), neutral white, glass diffuser arm L. 640mm, matt silver

- Complete with LD700.1-2SW LED driver and on/off rocker switch

Cable Manager



- Route cables from desk to floor
- Quickly install or remove the cables inside
- Keep the cables segregated from each other
- Easily fix it underside of the desk
- 5-piece extension kit for longer length is available

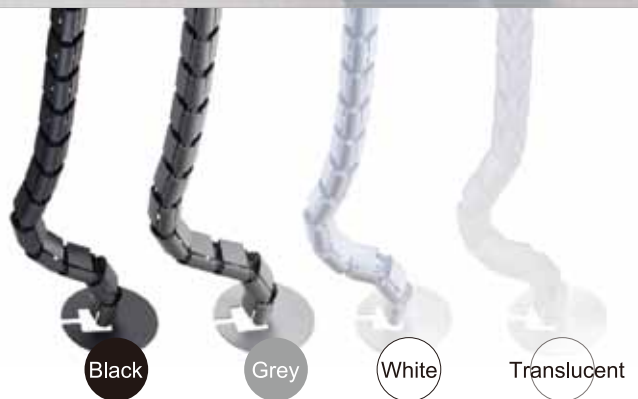

Black

Grey

White

Translucent

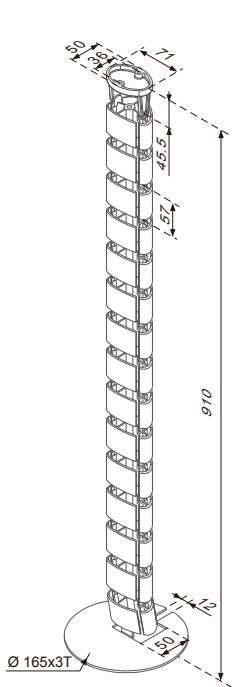

89920
screw mount type

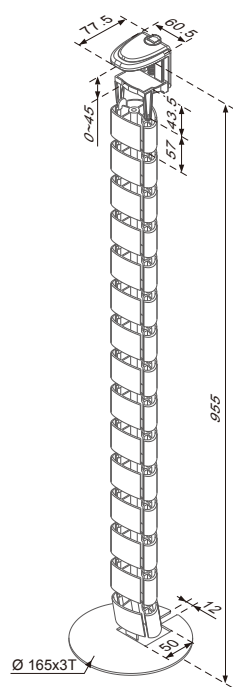

89921
clamp mount type

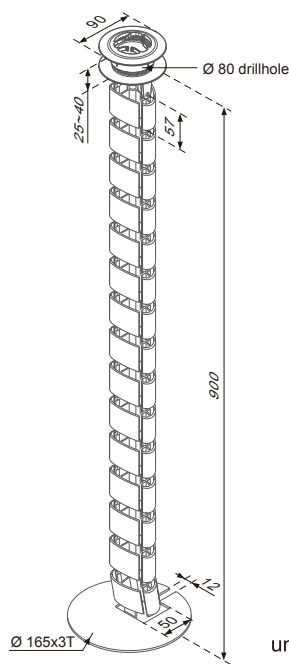

89923
grommet mount type

unit:mm



8992 5-Piece Extension Kit



89920 Vertical Cable Duct, screw mount type

- To conduct cables to the ground
- Screw fixing underneath desktop
- Regular length 890mm, can be adjusted by removing or adding duct segments
- Color: black, white, gray or translucent

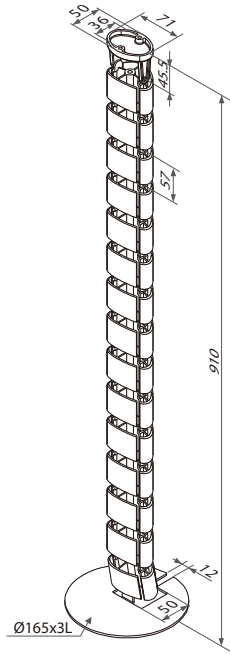

89921 Vertical Cable Duct , clamp mount type

- To conduct cables to the ground
- Clamp on desk top, max. 40mm thick
- Regular length 890mm, can be adjusted by removing or adding duct segments
- Color: black, white, gray or translucent

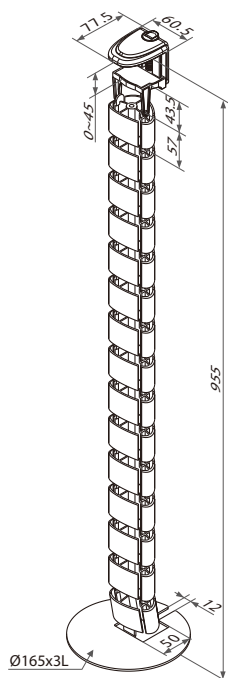

89923 Vertical Cable Duct, grommet mount type

- To conduct cables to the ground
- Grommet mount type with a drillhole of $\varnothing 80\text{mm}$
- Color: black, white, gray or translucent

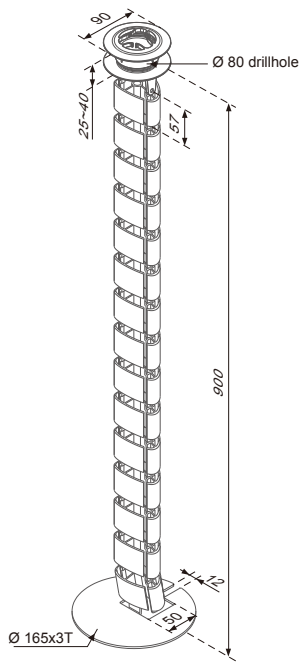

8992 5-Piece Extension Kit

- For the higher desks or bar stool
- For electric height adjustable desk, please add 1 or 2 kits

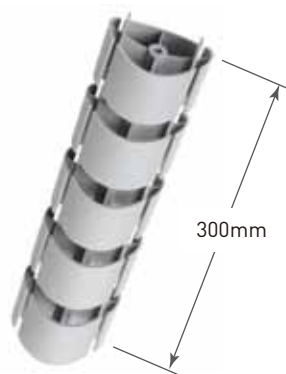

CONFERENCE Built-in Frame & PDU

Features:

■ Simple Yet Elegant

Conference integrates into the desk or table tops with an elegant appearance in a high-end design.

■ Easy-To-Access

Simply press with your thumb to release the magnetic catch & the opening flat swings up.

■ Spink-N-Span

The unit can be closed once devices have been plugged in without crushing the cable.



Long Version

Outer dimensions: L467 x W183 (mm) Built-in dimensions: L452 x W170 (mm) Built-in depth: 110 (mm)

Art. No. Descriptions

338.0200 Moonstone metallic

338.0221 Silver grey RAL9006



Long Version PDU (Approx. L444mm): 3 x Custom Modules; Aluminium Profile; Power Input GST 18i3

Art. No. Descriptions

909.0053 4 x UK45° black socket outlets
3.15A individually fused, child-proof



909.0049 6 x US black socket outlets
Child-proof



909.0045 5 x CCC black socket outlets
Child-proof



909.0052 4 x Universal black socket outlets



CONI Built-in Frame

Features:

- **Easy To Access**
Unrestricted access to power, media & data just simply by opening the cover.
- **Harmonious Appearance**
Coni integrates into the surface of the desk, table or partitions when not in use.
- **Clear & Neat**
Integrated brush insert for closing when cables are connected without jamming.

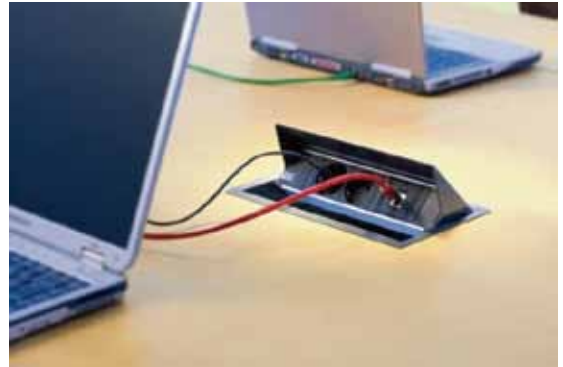

Short Version

Outer dimensions: L248 x W151 (mm) Built-in dimensions: L237 x W141 (mm)

Art. No.	Descriptions
----------	--------------

338.0203	Silver grey RAL9006
----------	---------------------

338.0204	Anthracite
----------	------------

911.002	Black RAL9005
---------	---------------

911.004	Ground stainless steel
---------	------------------------



Long Version

Outer dimensions: L387 x W151 (mm) Built-in dimensions: L375 x W141 (mm)

Art. No.	Descriptions
----------	--------------

338.0205	Silver grey RAL9006
----------	---------------------

338.0206	Anthracite
----------	------------

911.003	Black RAL9005
---------	---------------

911.005	Ground stainless steel
---------	------------------------



CONI PDU

Short Version PDU (Approx. L217mm) 1 x Custom Module; Aluminium Profile

Art. No. Descriptions

- 912.0701 2 x UK90° black socket outlets
Power input: 2.0M H05VV-F3G1.5mm², BS13A plug
3.15A individually fused, child proof
- 912.0951 3 x US black socket outlets
Power input: 2.0M SJT3C AWG14, NEMA5-15P plug
Child-proof
- 912.0161 2 x CCC black socket outlets
Power input: 2.0M RVV3G1.0mm², CCC10A plug
Child-proof
- 912.0711 2 x Universal black socket outlets
Power input: 0.1M H05VV-F3G1.5mm², GST18i3 plug



Long Version PDU (Approx. L356mm) 2 x Custom Modules; Aluminium Profile

Art. No. Descriptions

- 912.0661 3 x UK45° black socket outlets
Power input: 2.0M H05VV-F3G1.5mm², BS13A plug
3.15A individually fused, child proof
- 912.0681 6 x US black socket outlets
Power input: 2.0M SJT3C AWG14, NEMA5-15P plug
Child-proof
- 912.0162 4 x CCC black socket outlets
Power input: 2.0M RVV3G1.0mm², CCC10A plug
Child-proof
- 912.0163 3 x Universal black socket outlets
Power input: 0.1M H05VV-F3G1.5mm², GST18i3 plug

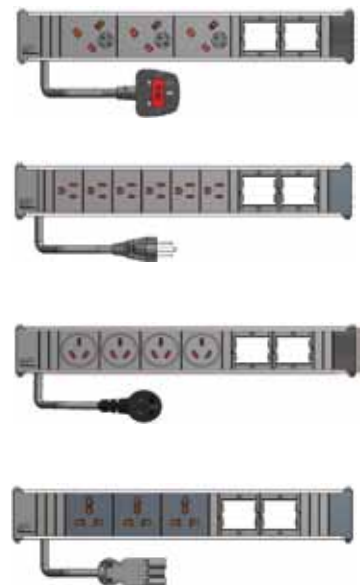

DESK 1 PDU

Features:

■ Flexibility

Desk is the ideal solution for power, media & data whenever workstations must be flexible.

■ Versatility

The unit can be mounted on desk/tabletops or can free-standing.

■ Safety Concern

With On/Off switch



With On/Off Switch PDU 1 x Custom Module; Aluminium Profile

Art. No. Descriptions

902.0109	3 x UK45° black socket outlets Power input: 2.0M H05VV-F3G1.5mm ² , BS13A plug 3.15A individually fused, child proof
902.0110	3 x US black socket outlets Power input: 2.0M SJT3C AWG14, NEMA5-15 plug Child-proof
902.0162	3 x CCC black socket outlets Power input: 2.0M RVV3G1.0mm ² , CCC10A plug Child-proof
902.0163	3 x Universal black socket outlets Power input: 0.1M H05VV-F3G1.5mm ² , GST18i3 plug



Without Switch PDU 1 x Custom Module; Aluminium Profile

Art. No. Descriptions

902.0164	3 x UK45° black socket outlets Power input: 2.0M H05VV-F3G1.5mm ² , BS13A plug 3.15A individually fused, child proof
902.0165	3 x US black socket outlets Power input: 2.0M SJT3C AWG14, NEMA5-15 plug Child-proof
902.0166	3 x CCC black socket outlets Power input: 2.0M RVV3G1.0mm ² , CCC10A plug Child-proof
902.0167	3 x Universal black socket outlets Power input: 0.1M H05VV-F3G1.5mm ² , GST18i3 plug



POWER FRAME Built-in Frame & PDU

Features:

- Compact Dimensions**
 The builtin frame can be installed on desk or table tops with minimum thickness of 10 (mm).
- Ease of Integration**
 The PDU clicks into the builtin frame, no tools are required.
- Timeless Design**
 Since the PDU can be interchanged at any time, the user is guaranteed long term flexibility & adaptability of future requirements.



Built-in Frame

Outer dimensions: L241.5 x W73 (mm) Built-in dimensions: L224.5 x W60 (mm) Built-in depth: 35.5 (mm)

Art. No.	Descriptions
317.000	Silver grey RAL9006
317.001	Stainless steel
915.000	Black RAL9005



PDU Approx. L220 (mm) 1 x Custom Module; Aluminium Profile

Art. No.	Descriptions
906.0291	2 x UK90° black socket outlets Power input: 2.0M H05VV-F3G1.5mm ² , BS13A plug 3.15A individually fused, child proof
916.0681	3 x US black socket outlets Power input: 2.0M SJT3C AWG14, NEMA5-15 plug Child-proof
916.0851	2 x CCC black socket outlets Power input: 2.0M RVV3G1.0mm ² , CCC10A plug Child-proof
916.0682	2 x Universal black socket outlets Power input: 0.1M H05VV-F3G1.5mm ² , GST18i3 plug

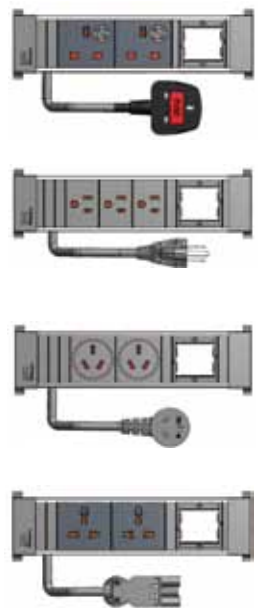

CUSTOM MODULES

For Custom Configuration



The advantages at a glance

- Modules are flexible in terms of interchangeability
- For data, video & audio connections
- Installation / replacement will not invalidate warranty since each individual frame is isolated

CUSTOM MODULES

Data Connections – Sockets

ISDN RJ45 Socket

Art No.	Description
940.112	Front: RJ45 (Keystone fixing) Rear: RJ45 (Keystone fixing) Unshielded



CAT6 Coupling Socket

Art No.	Description
940.083	Front: RJ45 (Keystone fixing) Rear: RJ45 (Keystone fixing) Shielded



ISDN RJ12 Socket

Art No.	Description
940.085	Front: RJ12 (Keystone fixing) Rear: RJ12 (Keystone fixing) Unshielded



CAT5e Adapter Socket

Art No.	Description
940.057	Front: RJ45 (Keystone fixing) Rear: RJ45 (Keystone fixing) Shielded



CUSTOM MODULES

Data Transmission

USB 3.0A

Art. No.	Descriptions
----------	--------------

917.120	Front: USB Socket A Rear: USB Socket A *Fits into Keystone frame 917.000 or 917.001 *Requires approx. 85mm installation depth
---------	--



For Networks, Media & Programming

Module 2 x Keystone

Art. No.	Descriptions
----------	--------------

917.000	Module, Black, accepts 2 data sockets with Keystone fixing
---------	--



Module 1 x Keystone

Art. No.	Descriptions
----------	--------------

917.001	Module, Black, accepts 1 data socket with Keystone fixing
---------	---



VGA + Stereo

Art. No.	Descriptions
----------	--------------

917.013	Front: 15-pin VGA Socket + Mini Jack – 3.5mm ² Socket Rear: VGA 15-pin Socket + 2 x Cinch Stereo Sockets (Red & White)
---------	---



www.conset.com

www.4winds.com.tw

Oversea offices and showrooms:

Singapore

Xplendid Co., Pte. Ltd

No. 8 Burn Road #01-02 Trivex Singapore 369977

T +65 6509 0181

F +65 6509 0793

E info@xplendid.sg

Dubai, UAE

Four Winds International

P.O.Box: 61172 Jebel Ali Free Zone Dubai, U.A.E.

T +971 4 881 2755

F +971 4 881 3363

E fourwind@emirates.net.ae

Ankara, Turkey

MOB Uluslararası Tasarım Aksesuarlar Tic.Ltd.St.

Uğur Mumcu Caddesi No: 89-B

06700 GOP Ankara, Turkey

T +90 312 446 4075

F +90 312 446 4075

E info@mobtasarimaksesuar.com



康萊興業股份有限公司
FOUR WINDS CORPORATION

11072 台北市基隆路一段176號12樓
12th Fl., No.176, Keelung Rd. Sec.1
Taipei 11072, Taiwan

T +886-2-2768-8389
F +886-2-2768-7955~7
E fw@fourwinds.com.tw